

FEATURES

- Plastic package has Underwriters Laboratory Flammability Classification 94V-0
- Metal silicon junction ,majority carrier conduction
- Guard ring for overvoltage protection
- Low power loss ,high efficiency
- High current capability ,Low forward voltage drop
- High surge capability
- For use in low voltage ,high frequency inverters, free wheeling ,and polarity protection applications
- Dual rectifier construction
- High temperature soldering guaranteed:260° C/10 seconds,, 0.25"(6.35mm)from case
- Component in accordance to RoHS 2002/95/EC and WEEE 2002/96/EC

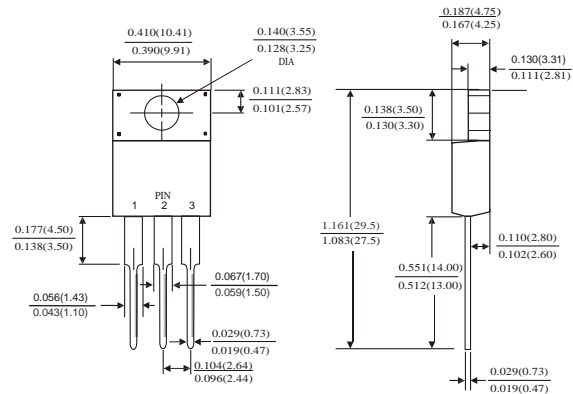

ITO-220AB



Dimensions in inches and (millimeters)

MECHANICAL DATA

- Case: JEDEC ITO-220AB molded plastic body
- Terminals: Lead solderable per MIL-STD-750,method 2026
- Polarity: As marked
- Mounting Position: Any
- Weight: 0.08ounce, 2.24 gram

MAXIMUM RATINGS AND ELECTRICAL CHARACTERISTICS

(Ratings at 25°C ambient temperature unless otherwise specified ,Single phase ,half wave ,resistive or inductive load. For capacitive load, derate by 20%.)

	Symbols	MBRF 1620CT	MBRF 1630CT	MBRF 1640CT	MBRF 1650CT	MBRF 1660CT	MBRF 1680CT	MBRF 16100CT	MBRF 16150CT	MBRF 16200CT	Units
Maximum repetitive peak reverse voltage	VRRM	20	30	40	50	60	80	100	150	200	Volts
Maximum RMS voltage	VRMS	14	21	28	35	42	56	70	105	140	Volts
Maximum DC blocking voltage	VDC	20	30	40	50	60	80	100	150	200	Volts
Maximum average forward rectified current(see Fig.1)	Per leg	8.0									Amps
	Total device	16.0									
Peak forward surge current 8.3ms single half sine-wave superimposed on rated load (JEDEC method)	IFSM	200.0									Amps
Maximum instantaneous forward voltage at 16.0 A	VF	0.60			0.75		0.85		0.90	0.95	Volts
Maximum instantaneous reverse current at rated DC blocking voltage(Note 1)	IR	0.2									mA
		30			50						
Typical thermal resistance (Note 2)	R JC θ	3.0									C/W
Operating junction temperature range	TJ	-65 to +150									C
Storage temperature range	TSTG	-65 to +150									C

Notes: 1.Pulse test: 300 μs pulse width,1% duty cycle
2.Thermal resistance from junction to case

[Http://www.gmsemi.com](http://www.gmsemi.com)

FIG.1-FORWARD CURRENT DERATING CURVE

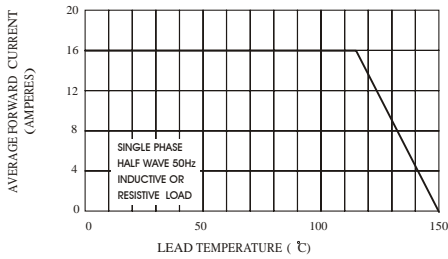

FIG.2-TYPICAL INSTANTANEOUS FORWARD CHARACTERISTICS

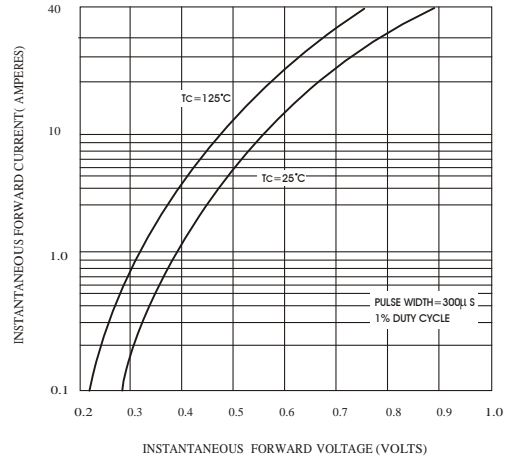

FIG.4-TYPICAL JUNCTION CAPACITANCE

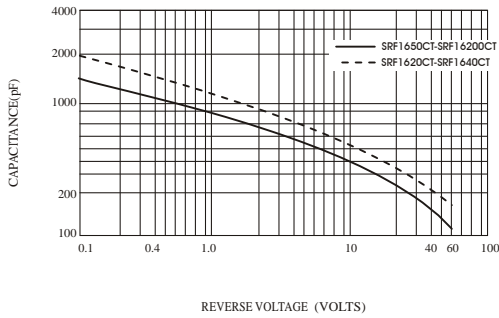

FIG.3-TYPICAL REVERSE CHARACTERISTICS

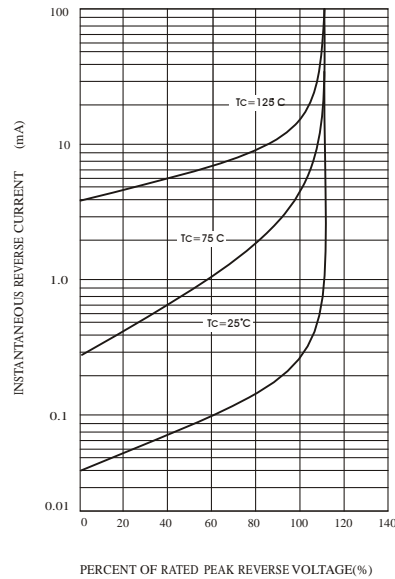

FIG.5-MAXIMUM NON-REPETITIVE PEAK FORWARD SURGE CURRENT

